

**ACCURATE BY DESIGN**  
**SENSOR SOLUTIONS**  
**FOR MATERIAL HANDLING**

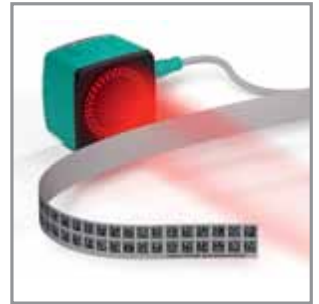

Pepperl+Fuchs is a leading developer and manufacturer of electronic sensors and components for the global automation market. We continually set new standards in quality and innovative technology.

**When it comes to speed, reliability and accuracy, Pepperl+Fuchs is your trusted partner.**

From logistics centers to warehouses and airports, reliable material handling is indispensable in a modern material flow system. Pepperl+Fuchs sensors guarantee trouble-free operation of your stock feeders and conveyor systems, and provide fast and safe material transport. Enjoy the smooth operation of your logistics processes without any collisions, failures or process interruptions. Our outstanding sensors also provide safety and accuracy in positioning of transport units in automated transport systems and industrial trucks.

Our experts help you select the right sensor technology for your specific application. Choose from our single source, wide product range. We also offer you an extensive choice of electrical and mechanical accessories for your sensor system solution.

With our global presence, reliable service and flexible production facilities, we deliver complete individual solutions for reliable and efficient operation of your systems.

Our experts will be happy to help you.

Tel.: +49 (0)621 776-1111

Fax: +49 (0)621 776-27-1111

E-Mail: [fa-info@pepperl-fuchs.com](mailto:fa-info@pepperl-fuchs.com)

Internet: [www.pepperl-fuchs.com/material-handling](http://www.pepperl-fuchs.com/material-handling)





## HIGH-BAY WAREHOUSES AND REFRIGERATED STORES

4



## CONTINUOUS CONVEYORS

6

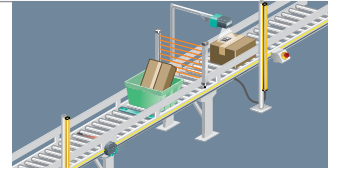

## OVERHEAD CONVEYORS

8

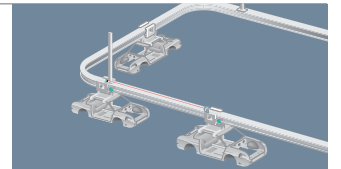

## CRANES

9

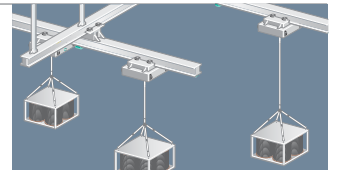

## AUTOMATED TRANSPORT SYSTEMS

10

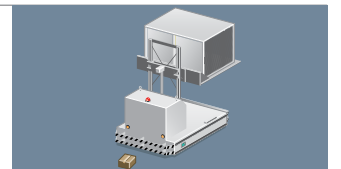

## FORKLIFTS

11



## SAFETY TECHNOLOGY

12

- Safety thru-beam sensors
- Safety rotary encoders

## DATA SECURITY

13

- RFID
- Data Matrix

## SENSING YOUR NEEDS

14

- Pulse Ranging Technology
- AS-Interface

## SENSORS FOR MATERIAL HANDLING

15

# HIGH-BAY WAREHOUSES AND REFRIGERATED STORES

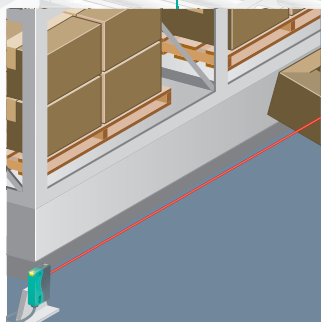
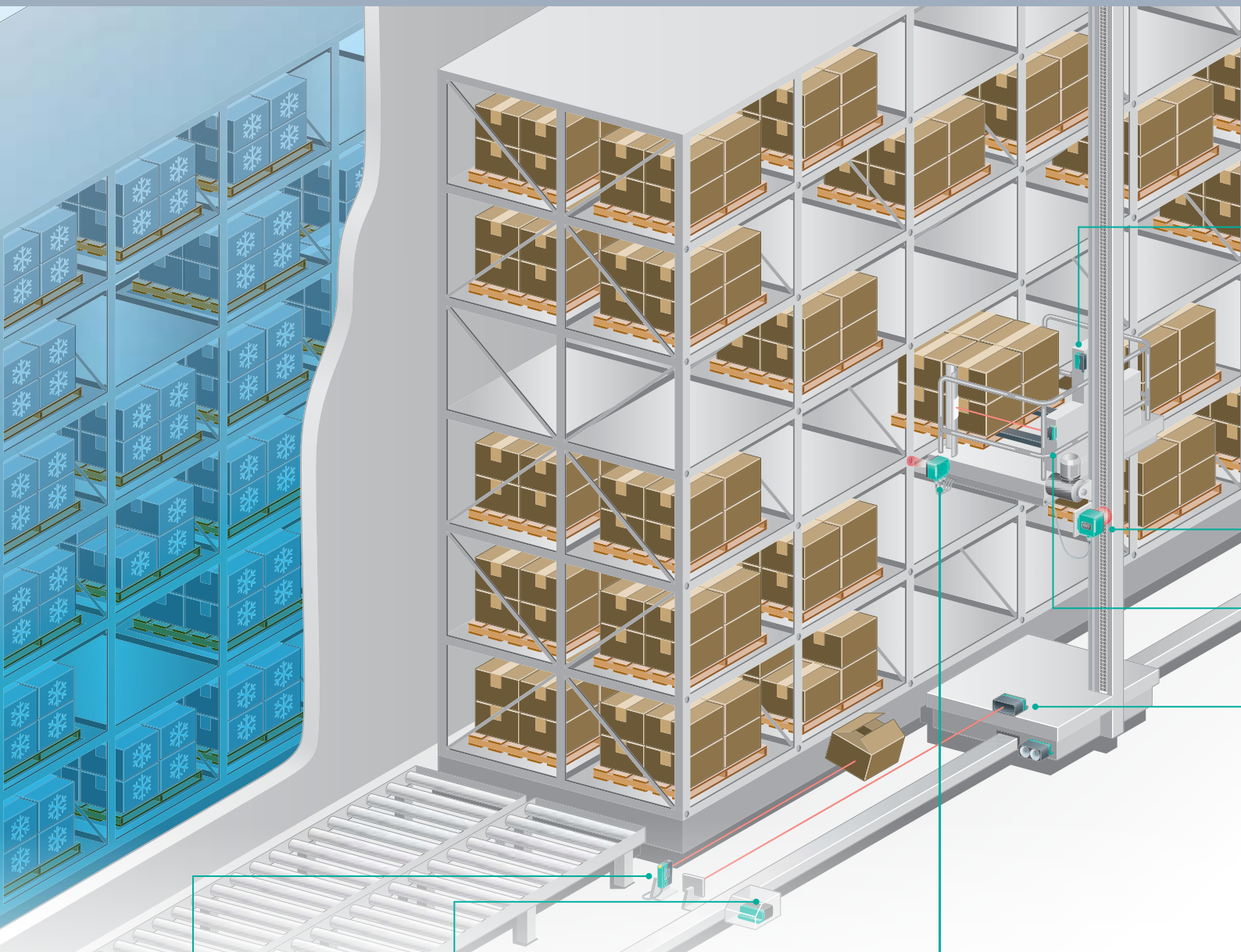

## GAP CONTROL

### LD28/LV28 THRU-BEAM SENSORS

- Prevents lane collisions
- Protects the whole shelving length up to 300 m
- No jamming of pallets or cartons

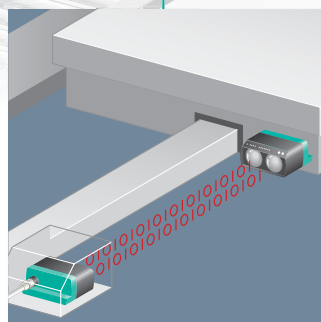

## DATA TRANSFER

### LS610, LS680 OPTICAL DATA COUPLERS

- Protocol-free, full duplex data transfer from the controller to the stock feeder
- Fast Ethernet (data rate 100 MBit/s), PROFIBUS or INTERBUS

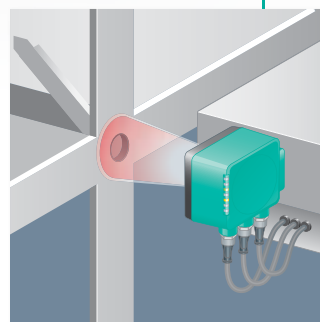

## RACK FINE POSITIONING

### FFPL520 VISION SENSOR

- Precise positioning with a slot on the shelf
- Large sensing range and detection/capture range of 100 mm x 120 mm
- Serial interface, Ethernet, switching outputs
- Compact design



### MONITORING THE RACK COMPARTMENT

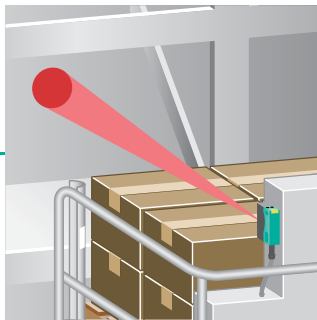

#### VDM28 DISTANCE SENSOR

- Reliable compartment detection
- Verifies pallet is inserted to correct distance
- Pulse Ranging Technology (PRT) precise measurement process
- Reliable background suppression

### OVERHANG CONTROL

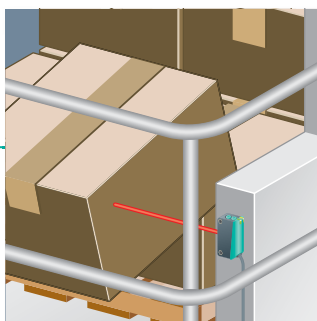

#### ML100 RETROREFLECTIVE SENSOR

- Position and end position detection
- Shifting of the load is reliably detected
- Insensitive to reflection and ambient light
- Protection against cross-talk
- Long sensing ranges up to 7 m

### POSITION OF THE LOAD SUSPENSION DEVICE (Y-DIRECTION)

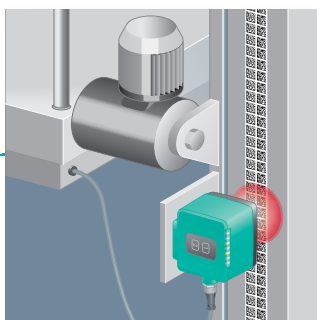

#### PCV DATA MATRIX POSITIONING SYSTEM

- Precise positioning with Data Matrix code strip
- High resolution of 0.1 mm
- Communication via industrial bus systems, SSI or serial interfaces
- No reference points, calibration or justification needed

### POSITION OF THE STOCK FEEDER (X-DIRECTION)

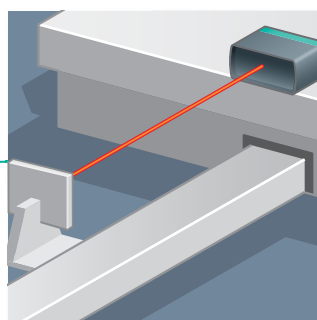

#### VDM100 DISTANCE MEASUREMENT DEVICE

- Precise positioning with Pulse Ranging Technology (PRT)
- Exact distance measurement to the reflector in the lane (up to 300 m)
- Eye-safe laser class I
- SSI interface, PROFIBUS, INTERBUS

## OPTICAL IDENTIFICATION

### MAC401 HIGH-SPEED 1D AND 2D CODE READER

- Fast and reliable reading of 1D and 2D codes
- Also reads damaged codes (code reduction)
- Ultra-fast response times

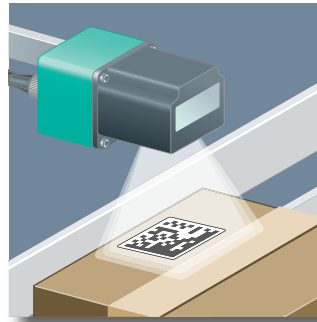

## OVERHANG CONTROL

### LGS AUTOMATION LIGHT GRID

- Programmable beam pattern
- High resolution
- Protects products and system parts
- Configurable via touch field or external input
- Temperature range -30 °C to +60 °C
- IO-Link interface

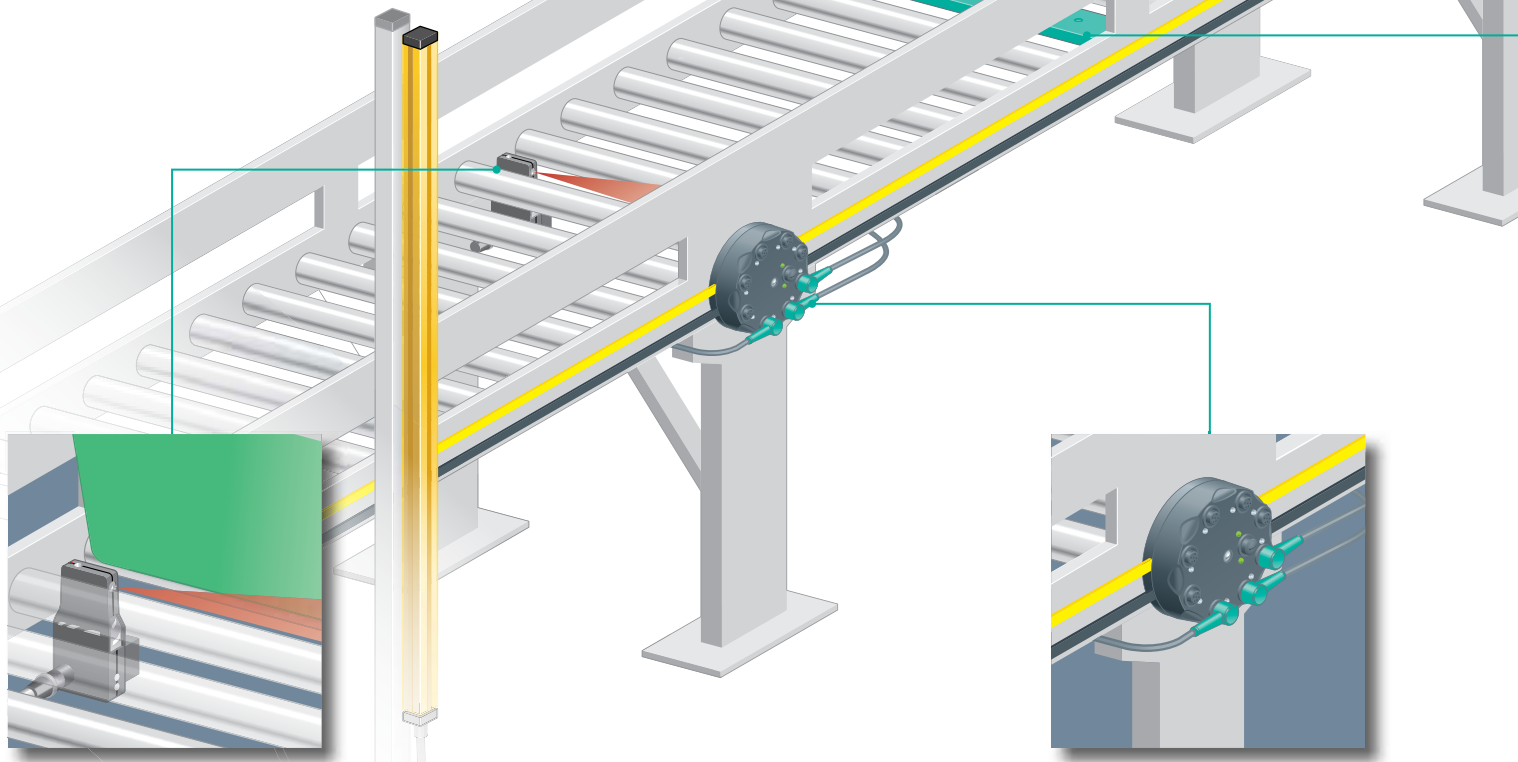
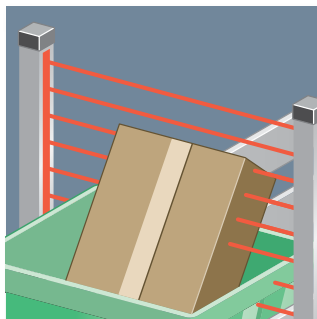

## OBJECT DETECTION ON ROLLER CONVEYORS

### SBL-8-H DIFFUSE MODE SENSORS

- Monitors the entire width of the roller conveyor
- Integrated controller with pneumatic interface
- Background suppression
- Mounts between the rollers

## INTELLIGENT WIRING

### G11 AS-INTERFACE

- Easy connection of the sensors and actuators
- Space-saving cabling
- No troubleshooting with fault indication directly at the affected M12 port
- Round, compact design
- Standardized interfaces

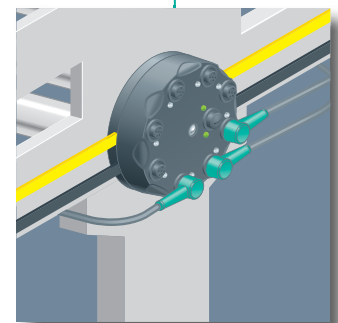

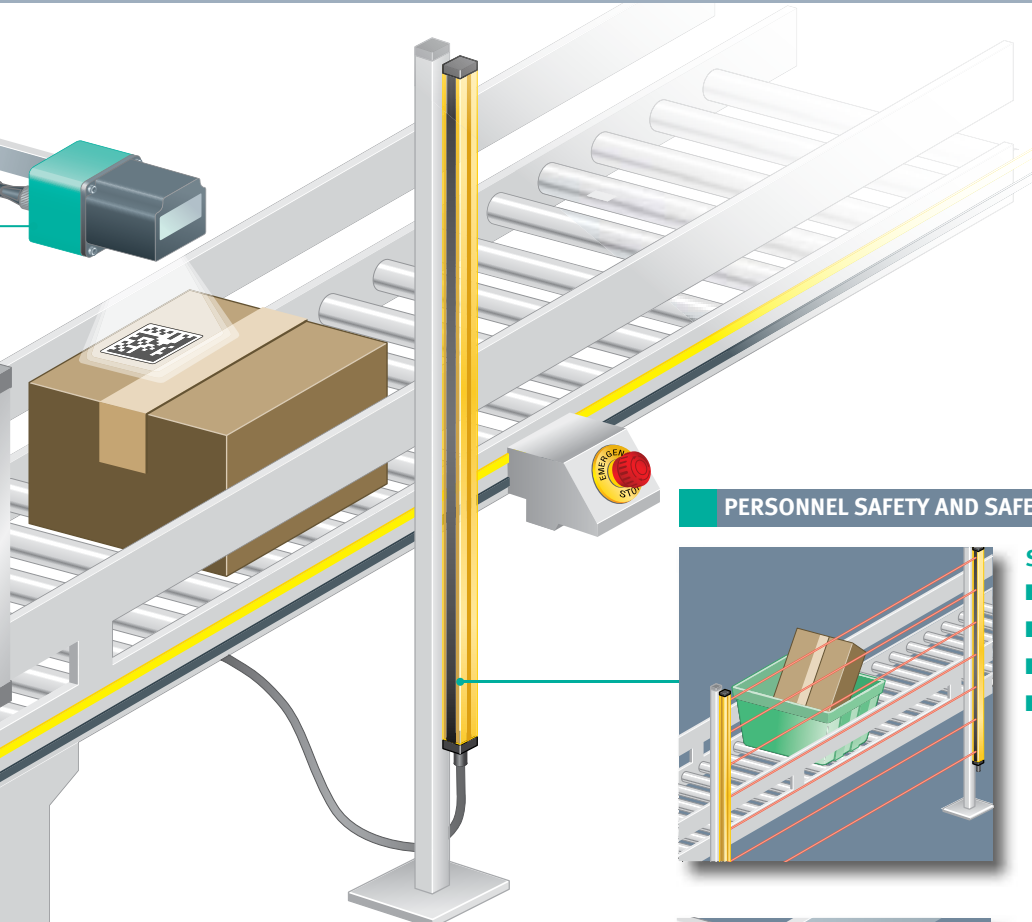

**PERSONNEL SAFETY AND SAFETY PROTECTION**

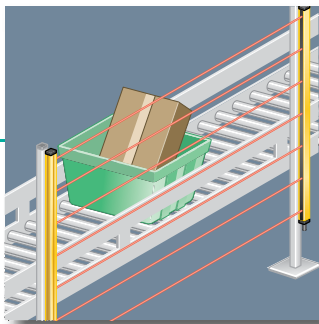

**SLCS, SLCT SAFETY LIGHT CURTAINS**

- High resolution and dense sensing field
- SIL2 (SLCT) and SIL3 (SLCS) safety certification
- Long sensing range up to 8 m
- Integrated evaluation

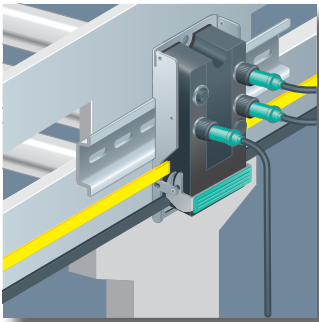

**G12 AS-INTERFACE SAFETY MODULE CONNECTION OPTION**

- Space-saving cabling
- Quick and easy DIN rail mounting
- No troubleshooting with fault indication directly at the affected M12 port
- Networking of all safety devices via AS-Interface Safety at Work

**CONTAINER IDENTIFICATION**

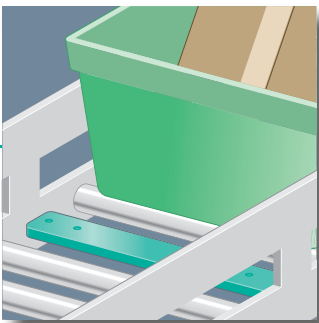

**F97 RFID READ/WRITE HEAD**

- Wide sensing range of 50 cm guarantees reliable tag reading
- Mounts between or along the side of the conveyor rollers
- Interfaces for all common industrial bus systems
- Tags are available with various designs, sensing ranges and data volumes

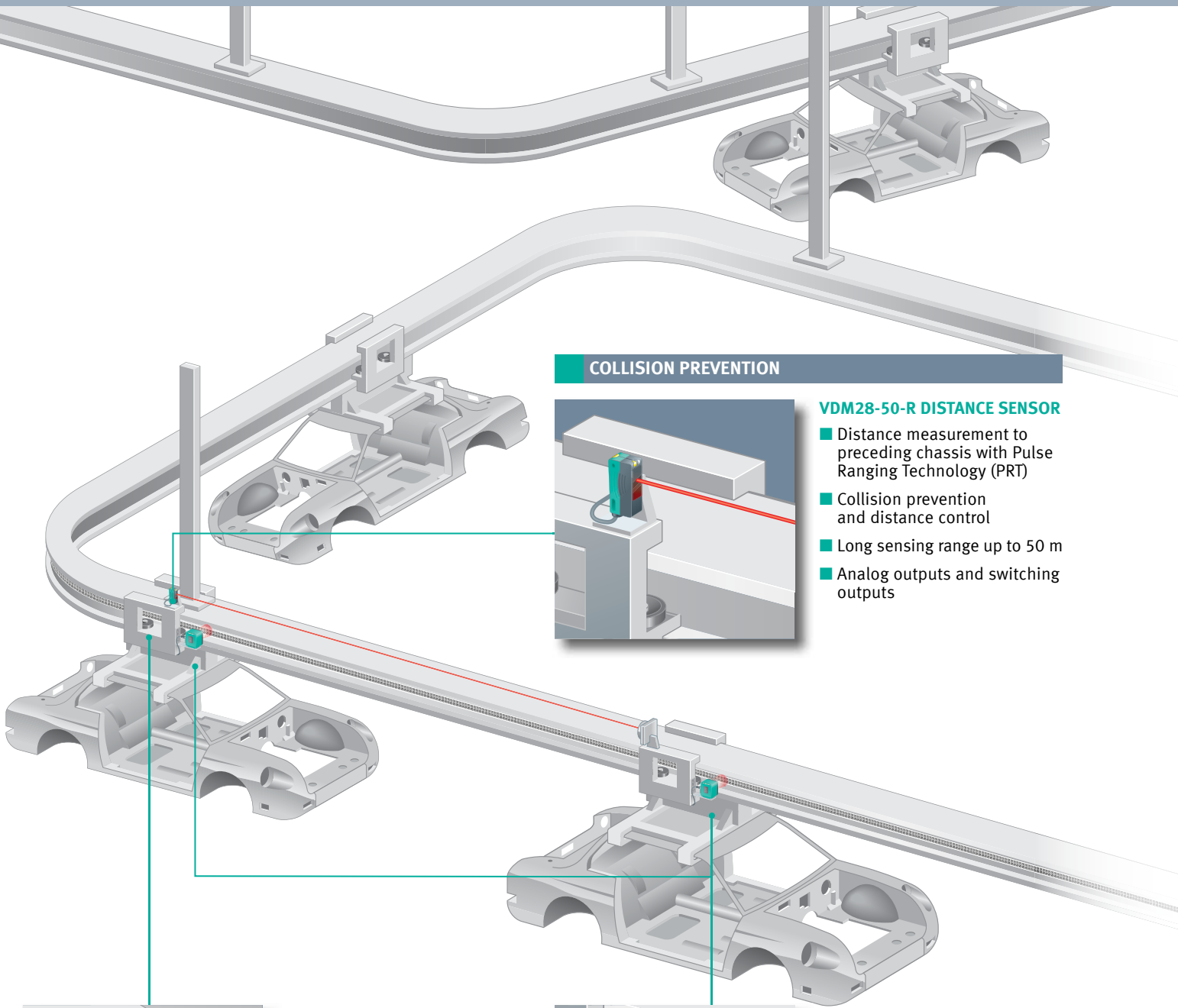

## COLLISION PREVENTION

### VDM28-50-R DISTANCE SENSOR

- Distance measurement to preceding chassis with Pulse Ranging Technology (PRT)
- Collision prevention and distance control
- Long sensing range up to 50 m
- Analog outputs and switching outputs

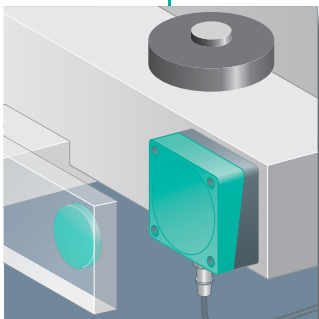
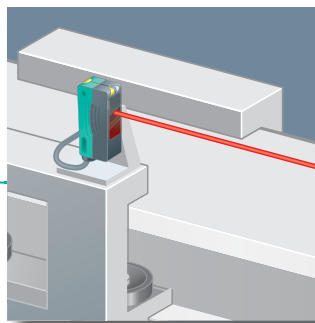

## MOBILE DATA STORAGE

### RFID IDENTIFICATION SYSTEM

- Chassis identification
- Stores production data
- Data retrieval for quality assurance
- Various fieldbus connections via IDENTControl interface

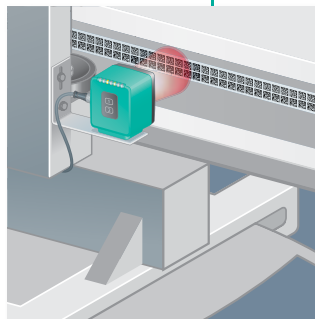

## SUSPENSION POSITIONING

### PCV DATA MATRIX POSITIONING SYSTEM

- Exact position detection in x and y directions
- Highest data security, because of insensitivity to dirt or damage to the Data Matrix code strip
- Reliable measurement at speeds up to 12.5 m/s
- Slim code band for the narrowest of mounting sites and distances up to 10,000 m
- Extremely robust with a long service life



## ABSOLUTE POSITIONING

### WCS POSITION ENCODING SYSTEM

- Absolute positioning via non-contact measurement
- High resolution
- Reliable measurement at speeds of up to 12.5 m/s
- Robust housing for use in harsh and dirty environments

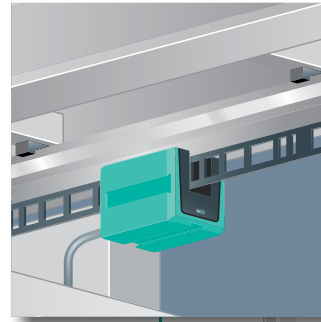

## HEIGHT CONTROL

### CVM58S SAFETY ABSOLUTE ROTARY ENCODERS

- Safe positioning of the vertical lift height for systems up to SIL3 and PLe
- Certified functional safety

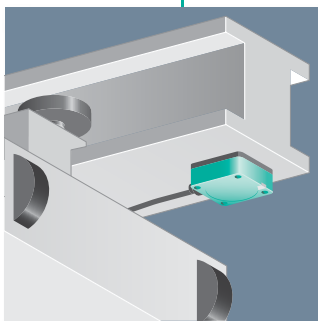
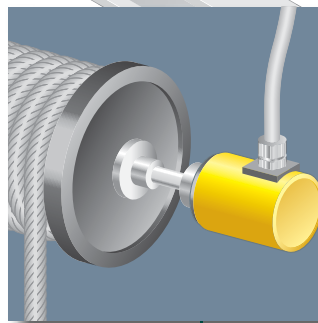

## END POSITION DETECTION

### INDUCTIVE SENSORS

- Robust and cost-effective
- Large selection of products and designs

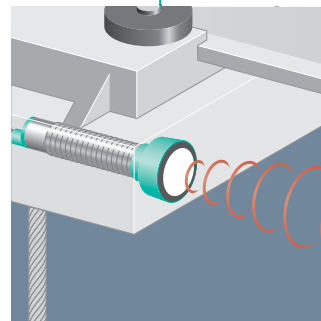

## COLLISION PREVENTION

### UC SERIES ULTRASONIC SENSORS

- Distance measurement
- Insensitive to dust and dirt
- Current or voltage output

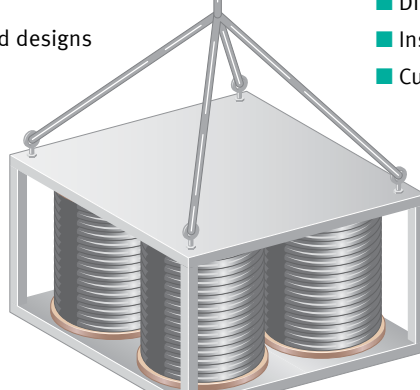

## DATA TRANSFER

### DAD15 OPTICAL DATA COUPLER

- Infrared transfer of control data at the origination or destination station
- Long sensing ranges
- Increased noise immunity
- Parallel data transfer

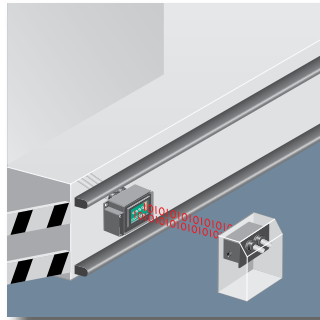

## COLLISION PREVENTION

### UC SERIES ULTRASONIC SENSORS

- Fast response time
- Simple programming of sensing range and switching points
- Insensitive to dust, noise and color
- Sensing ranges up to 6 m

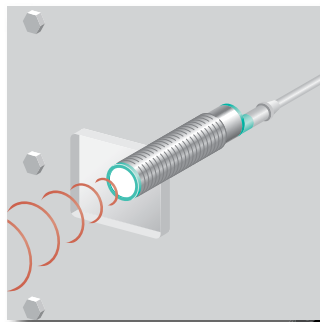

## SAFETY MONITORING

### VARIKONT SERIES INDUCTIVE SENSORS

- Reliable end position detection to prevent collisions
- Robust housing
- Flexible mounting options

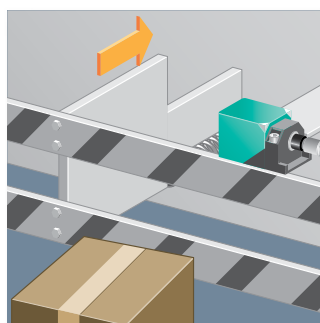

### G12 AS-INTERFACE SAFETY MODULE CONNECTION OPTION

- Space-saving cabling
- Quick and easy DIN rail mounting
- No troubleshooting with fault indication directly at the affected M12 port
- Networking of all safety devices via AS-Interface Safety at Work

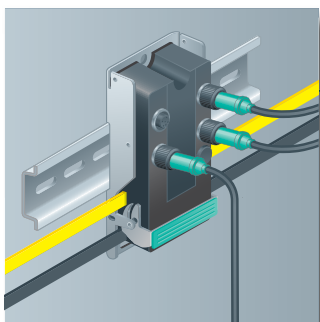

## SPEED AND DIRECTION MONITORING

### RVS58S AND CVM58S SAFETY ROTARY ENCODERS

- CVM58S absolute rotary encoder to monitor turning angle and direction
- RVS58S incremental rotary encoder reliably monitors the travel speed
- Certified functional safety up to SIL3 and PL<sub>e</sub>

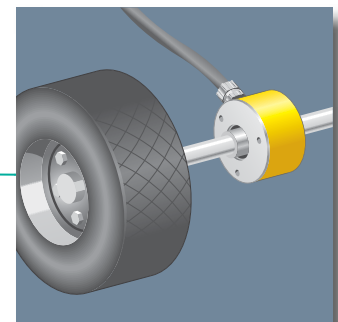

## FORK INCLINATION

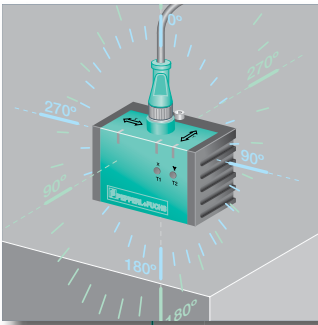

### F99 INCLINATION SENSOR

- Ensures forks are level when the forklift is moving
- Prevents tipping of the forklift when moving heavy loads
- Easy mounting

## NON-MECHANICAL HAND DETECTION



### F46 CAPACITIVE GRIP SENSOR

- When joystick is released, the engine shuts down
- Flat design
- Customer-specific solution

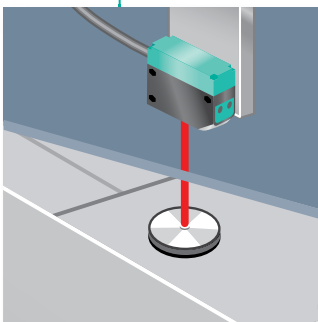

## FORK HEIGHT CONTROL

### VDM28 DISTANCE SENSOR

- Monitors fork height to ground for safe fork movement
- Forklift movement according to fork height
- Exact measurement with Pulse Ranging Technology (PRT)

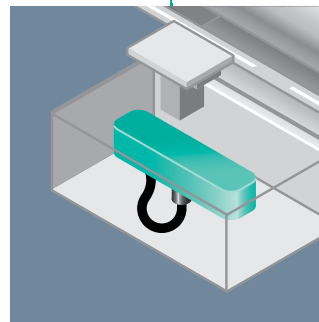

## FORK EXTENSION CONTROL

### PMI120-F90 INDUCTIVE POSITIONING SYSTEM

- Monitors the fork position
- Robust design
- Wear-free and soil-resistant

## SAFETY THRU-BEAM SENSORS

Safety means protection against danger. Protecting people and preventing accidents is increasingly important in automated processes.

Pepperl+Fuchs offers a comprehensive range of non-contact protective devices and cost-effective safety-related system solutions to prevent machine-related risks.



From single-beam safety thru-beam sensors to multi-beam machine protection – our products support effective solutions for functional safety. The modular SafeBox and AS-Interface Safety at Work evaluation unit complete the range.

## SAFETY ROTARY ENCODERS

Rotary encoders are used where physical values such as rotational speed, acceleration, velocity, and direction need to be detected. Systems and component manufacturers are faced with higher demands for functional safety.

Whether in overhead conveyors, conveyor systems, or other systems that fall within the field of applications covered by the European Machinery Directive 2006/42/EC, safety rotary encoders from Pepperl+Fuchs enable economical system integration through innovative concepts.

Play it safe and trust Pepperl+Fuchs:

- Certified functional safety
- Incremental/absolute rotary encoder technology
- For systems up to SIL3 according to IEC 61508
- Performance Level e according to ISO 13849
- Safety category 4 according to EN 954-1
- For electrical drives according to IEC 61800-5-2





## RFID

Pepperl+Fuchs provides perfectly matched components to set up a high-performance RFID system that can be quickly adapted to new requirements. The building blocks of any RFID system are the RFID read/write heads, tags, and control units.

Our RFID **IDENTControl** and **IDENTControl Compact** interfaces

- Act as the gateway to the control, communication, and power supply to the read/write heads
- Filter read data
- Feature interfaces for all common industrial bus systems, such as PROFIBUS, PROFINET and Ethernet



## DATA MATRIX

The two-dimensional Data Matrix code is an intelligent enhancement of the one-dimensional barcode.

The Data Matrix technology used for identification is based on modern image processing and is distinguished by:

- Extremely high data reliability
- Storage of high data volumes with minimal space requirements
- High read speed

From stationary code readers for high-speed reading to handheld readers for industry, Pepperl+Fuchs offers a wide range of 1D and 2D code identification products. All Data Matrix readers support automatic error correction without loss of data.

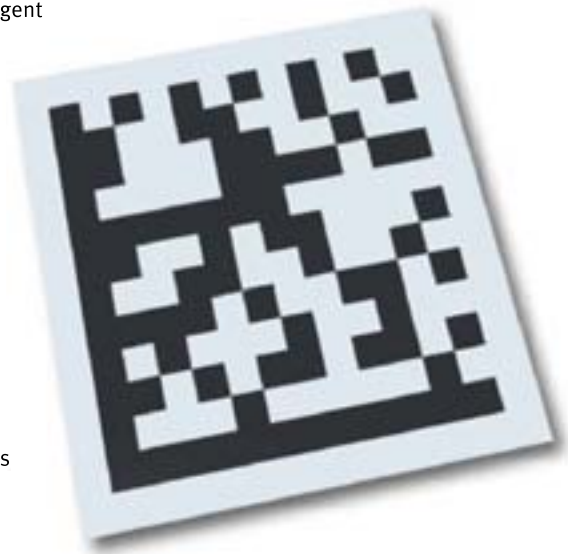

## DISTANCE MEASUREMENT WITH PULSE RANGING TECHNOLOGY – SENSING BY RANGING

Are you searching for a powerful distance measurement sensor that provides accurate measurements?

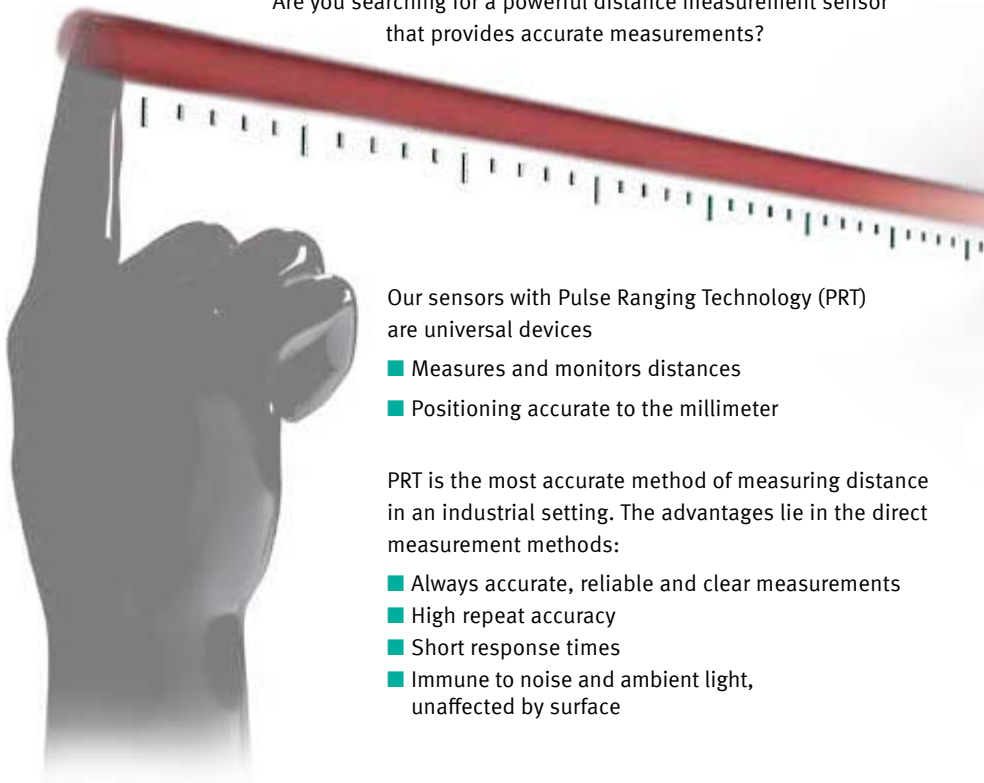

Our sensors with Pulse Ranging Technology (PRT) are universal devices

- Measures and monitors distances
- Positioning accurate to the millimeter

PRT is the most accurate method of measuring distance in an industrial setting. The advantages lie in the direct measurement methods:

- Always accurate, reliable and clear measurements
- High repeat accuracy
- Short response times
- Immune to noise and ambient light, unaffected by surface



## AS-INTERFACE



The Actuator Sensor Interface (AS-Interface) with special yellow flat cable supplies power to the sensors and actuators and enables data transfer to a maximum of 62 modules per AS-Interface network.

The installation time and costs are much lower compared to conventional wiring technology. AS-Interface transfers data reliably, is extremely resistant to electromagnetic interference, has a diagnostic function, and can detect faults such as short circuits.

Pepperl+Fuchs offers you a wide range of products for your AS-Interface network:

- Masters and gateways for connecting to higher-level fieldbuses
- Large selection of slaves and power supplies
- Sensors with integrated AS-Interface chip
- Components for AS-Interface Safety at Work
- Versatile connection and mounting sets



## STANDARD PHOTOELECTRIC SENSORS

### ML100, RL28, RL29, RL31 SERIES

- Precise and non-contact detection, acquisition and monitoring
- Retroreflective and thru-beam sensors
- Background suppression sensor
- Wide range of designs and models



## PHOTOELECTRIC DISTANCE SENSORS

### VDM28, VDM100 SERIES

- Distance measuring using Pulse Ranging Technology (PRT)
- Sensing ranges up to 300 m
- Accurate to 0.1 mm
- Distance measurements directly to objects or reflectors
- Suitable for low-temperature applications to -30 °C



## PHOTOELECTRIC SAFETY SENSORS

### SLCS, SLCT SERIES SAFETY LIGHT CURTAINS AND SAFEBOX

- From individual safety thru-beam sensors to multi-beam machine protection
- Finger protection, hand protection and body protection
- Integrated evaluation or evaluation using SafeBox



## AUTOMATION LIGHT GRIDS

### LGS SERIES

- Contour and height detection
- Sensing ranges up to 8 m
- Software-free configuration via touch field or external input
- Suitable for low-temperature applications to -30 °C



## OPTICAL DATA COUPLERS

### LS610, LS680, DAD15

- Optical data transfer up to a sensing range of 300 m
- PROFIBUS, INTERBUS, Ethernet (data rate 100 MBit/s) and serial communication possible



## SAFETY ROTARY ENCODERS

### RVS58S, CVM58S SERIES

- Incremental and absolute rotary encoders
- Certified functional safety for plants up to SIL3 and PLE



## POSITIONING SYSTEMS

### PCV DATA MATRIX POSITIONING SYSTEM

- Read head with modern camera technology
- Self-adhesive, robust Data Matrix code strip serves as information carrier
- Exact position detection in x and y directions with distances up to 10,000 m



### WCS2B, WCS3B POSITION ENCODING SYSTEMS

- Exact, absolute positioning with long travel paths
- Code rail in robust stainless steel or light plastic
- Reliable, even in the event of power failure



## OPTICAL IDENTIFICATION

### VB14, VB34, MAC335, MAC401 SERIES

- Reliable 1D and 2D code reading
- High-speed reading up to 10 m/s
- Stationary scanners and readers
- Handheld scanner



## RFID IDENTIFICATION

### IDENTCONTROL AND IDENTCONTROL COMPACT INTERFACES

- Control of the read/write operation
- Support for all RFID frequencies
- Interfaces for all common field bus systems



## INCLINATION SENSORS

### F99 SERIES

- Customer-specific configuration of measuring ranges and outputs
- Measurement range 0° to 360°
- Current, voltage and switching outputs, CANopen
- Robust and wear-free



## ULTRASONIC SENSORS

### UB, UC SERIES; 30GM, FP DESIGNS

- Non-contact distance measurement using ultrasound technology
- Robust design
- Immune to dirt
- Analog or switching outputs



## INDUCTIVE SENSORS

### M8, M12, M18, M30, VARIKONT-L, FP

- Robust design
- Up to IP68 and IP69K protection
- Suitable for low-temperature applications to -40 °C
- Wide variety of models



# FACTORY AUTOMATION – SENSING YOUR NEEDS



Pepperl+Fuchs sets the standard in quality and innovative technology for the world of automation. Our expertise, dedication, and heritage of innovation have driven us to develop the largest and most versatile line of industrial sensor technologies and interface components in the world. With our global presence, reliable service, and flexible production facilities, Pepperl+Fuchs delivers complete solutions for your automation requirements – wherever you need us.

## Contact

Pepperl+Fuchs GmbH  
Lilienthalstraße 200  
68307 Mannheim · Germany  
Tel. +49 621 776-4411 · Fax +49 621 776-27-4411  
E-mail: [fa-info@pepperl-fuchs.com](mailto:fa-info@pepperl-fuchs.com)

## Worldwide Headquarters

Pepperl+Fuchs GmbH · Mannheim · Germany  
E-mail: [fa-info@pepperl-fuchs.com](mailto:fa-info@pepperl-fuchs.com)

## USA Headquarters

Pepperl+Fuchs Inc. · Twinsburg, OH · USA  
E-mail: [fa-info@us.pepperl-fuchs.com](mailto:fa-info@us.pepperl-fuchs.com)

## Asia Pacific Headquarters

Pepperl+Fuchs Pte Ltd · Singapore  
Company Registration No. 199003130E  
E-mail: [fa-info@sg.pepperl-fuchs.com](mailto:fa-info@sg.pepperl-fuchs.com)

[www.pepperl-fuchs.com](http://www.pepperl-fuchs.com)

 **PEPPERL+FUCHS**  
SENSING YOUR NEEDS